



General Description

The P350W2-6CP SSPA is a high power, broadband, solid state power amplifier housed in a ruggedized rack mount chassis. The SSPA incorporates a wide input range multimode DC–DC converter power supply with a compact forced air-cooled design. The amplifier is appropriate for high–power wide–band susceptibility testing, communications, radar, or any application requiring instantaneous power amplification of signals across the 2.0–6.0 GHz frequency band.

The P350W2-6CP incorporates high efficiency GaN MMICs, spatially combined in a compact structure to achieve robust, high performance power amplification across the entire band. The high-speed gating feature not only gates off the spatium but also the low power driver amplifier to ensure ultra-low noise interpulse power levels. This high-speed gating feature also includes the ability to envelope the RF signal inside the gating signal by using leading and trailing edge time delays adjustable over the ethernet communication link.

The Polarity amplifier is designed to have a wide input range DC to DC converter with extremely low output voltage ripple that operates in CW and pulse regulation modes. The output regulation guarantees very low pulse to pulse noise and low pulse droop performance on the RF output signal.

Rear Panel Connections



P350W2-6CP



Product features

- Operating frequency: 2.0–6.0 GHz
- Output power: 350 Watts saturated power
- Gating frequency: 100kHz, burst to 1MHz
- VDS gating: 50ns rise and fall times
- RF Gating: <5ns rise and fall times
- RF droop: 0.1dB @ 100us pulse widths
- Small signal gain: 65 dB nominal
- Saturated gain: 55 dB nominal
- Input voltage: 22-32VDC
- Weight: 60lbs
- Monitor and Control: Ethernet
- Cooling: Forced air
- Enclosure: Rack mountable

Applications

- Radar
- Communications
- Test and Measurement
- EMI Testing

Ordering Information

Part No.	ECCN	Description
P350W2-6CP	3A611.X	2-6GHz 350W SSPA



SSPA Frequency vs. Power @ 35C

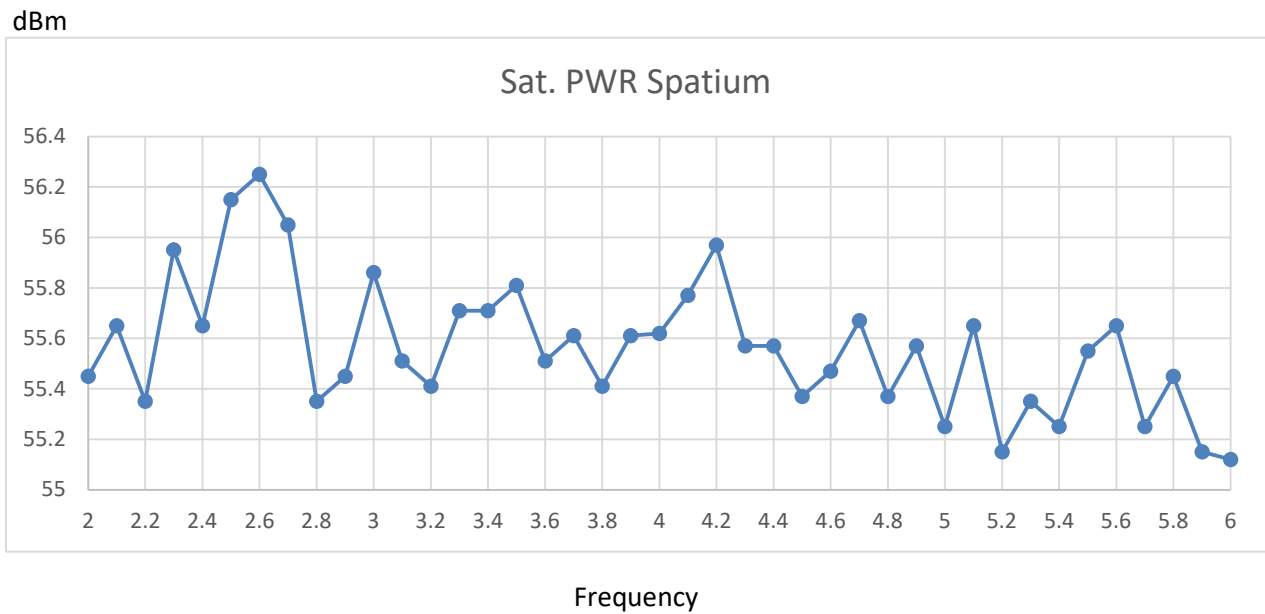

Functional Block Diagram

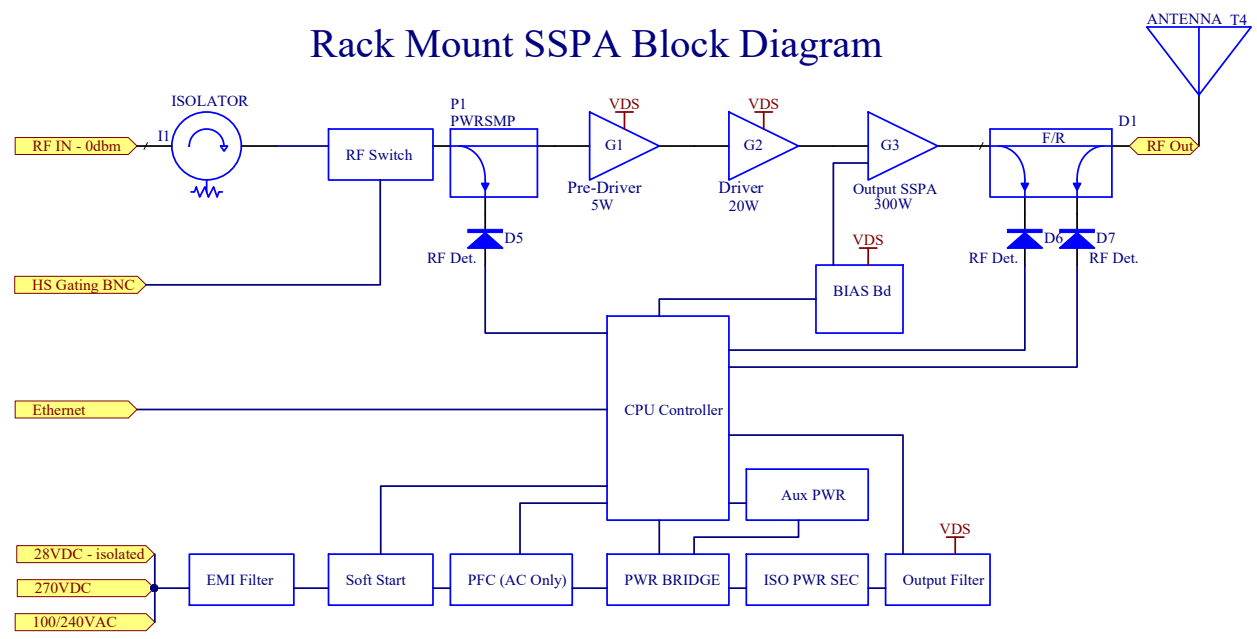



I/O Port	Label	Description
RF In	RF Input	SMA RF Input
RF Out	RF Output	N-type
DC Input	VDC	3 Pin Circular Power Connector - optional
Ethernet	Comms	RJ45 Circular Connector

Package Marking and Dimensions

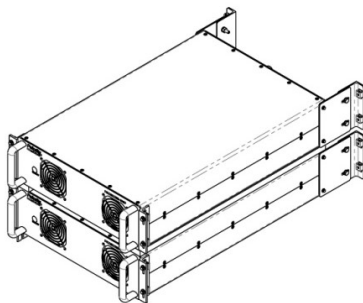
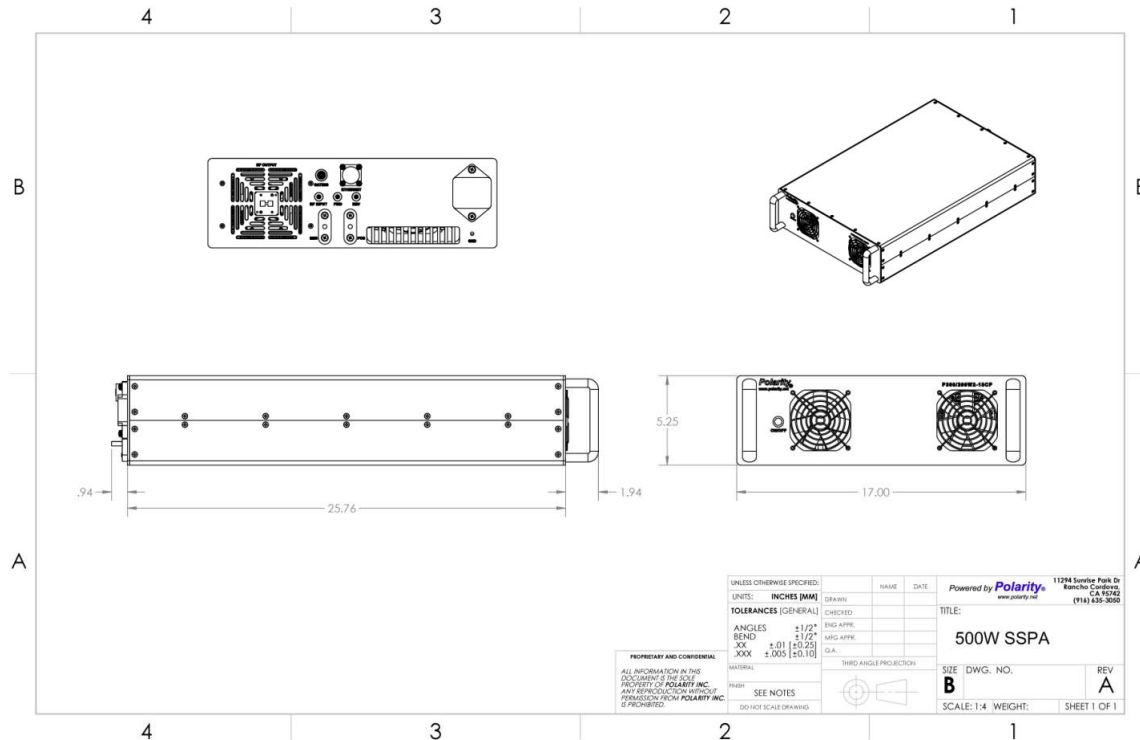

VIEW FOR REFERENCE ONLY



Caution ESD - Sensitive Device



Absolute Maximum Ratings

Parameter	Rating
RF Input Power, CW, 50 Ω , T _{CASE} =25 °C	+10 dBm
Load VSWR	3.0:1
DC Current (22, 28, 30VDC)	60,50, 45 A
Storage Air Temperature	-30 to +75 °C
Operating Air Temperature	-5 to +50 °C

Recommended Parameters

Parameter	Min	Typ	Max	Units
Voltage (V _{dc})	22	28	30	Volts
Current (dc)	55	45	40	Amps
Operating Air Temperature	-20	25	40	°C
RF Input Power, CW		0	+10	dBm